

Standard Features

- Turbine driven for irrigation or wastewater.
- Turbine and gearbox assembly no belts or pulleys.
- 4-Speed gearbox for high-speed light applications.
- PTO Wind-in.
- Automatic speed compensation.
- Digital Rainstar 060 tachometer with solar panel.
- Pressure gauge
- Adjustable width galvanized cart.
- Automatic cart lifting.
- 12-foot heavy-duty rubber supply hose.
- Supply hose adapter (female bauer).
- Galvanized chassis, drum and frame.
- Hydraulically operated galvanized stabilizer legs.
- 360 degree rotation turntable.

P.E. Pipe O.D.: 4.7" (120 mm)			P.E. Pipe I.D.: 4.0" (102 mm)				P.E. Pipe Length: 885' (270 m)								
120 gx 885 							SPEED OF P.E. PIPE PULL IN METERS/HOUR								
							15	20	25	30	40	50	60	100	
SPRINKLER: KOMET TWIN 202 ULTRA							SPEED OF P.E. PIPE PULL IN FEET/HOUR								
							50	65	80	100	130	165	195	325	
INLET PRESSURE (PSI)	NOZZLE PRESSURE (PSI)	NOZZLE SIZE (MM)	WATER FLOW (GPM)	SPRAY RANGE (FEET)	SPACING (FEET) 85%	ACRES PER PULL	PRECIPITATION RATE IN INCHES								
83	60	28 (1.10)	272	173	300	7.1	1.6	1.3	1.0	0.8	0.6	0.5	0.4	0.3	
97	70		294	182	300	7.2	1.8	1.4	1.1	0.9	0.7	0.5	0.4	0.3	
110	80		314	190	300	7.2	1.9	1.5	1.2	0.9	0.7	0.6	0.5	0.3	
89	60	30 (1.18)	312	178	300	7.2	2.0	1.5	1.2	1.0	0.8	0.6	0.5	0.3	
103	70		337	190	330	7.9	1.9	1.5	1.2	0.9	0.7	0.6	0.5	0.3	
117	80		360	198	330	8.0	2.0	1.6	1.3	1.0	0.8	0.6	0.5	0.3	
96	60	32 (1.26)	357	184	330	7.9	2.1	1.6	1.3	1.0	0.8	0.6	0.5	0.3	
109	70		386	197	330	8.0	2.2	1.7	1.4	1.1	0.9	0.7	0.6	0.3	
119	80		412	206	330	8.0	2.4	1.9	1.5	1.2	0.9	0.7	0.6	0.4	
99	60	34 (1.34)	400	190	330	8.0	2.4	1.9	1.5	1.2	0.9	0.7	0.6	0.4	
112	70		433	204	360	8.7	2.2	1.7	1.4	1.1	0.8	0.7	0.6	0.4	
130	80		462	213	360	8.8	2.6	2.0	1.6	1.3	1.0	0.8	0.7	0.4	
115	60	38 (1.50)	501	203	360	8.7	2.5	2.0	1.6	1.3	1.0	0.8	0.7	0.4	
132	70		541	217	360	8.8	2.7	2.5	1.8	1.4	1.1	0.9	0.7	0.4	
149	80		575	228	360	8.9	2.9	2.3	1.8	1.5	1.1	0.9	0.8	0.5	
ESTIMATED TIME FOR COMPLETE WINDING IN HOURS → → →							17.5	13.5	11.0	8.5	6.5	5.5	4.5	2.5	

Performance data has been obtained under ideal test conditions and may be adversely affected by wind, poor inlet pressure conditions or other factors.

No representation regarding droplet condition, uniformity, application rate or suitability for a particular application is made herein.

Operating at lower or higher pressures than stated above may result in warranty being voided.

Acreage is based on 1-inch application, 15 hours a day, 7 days a week.

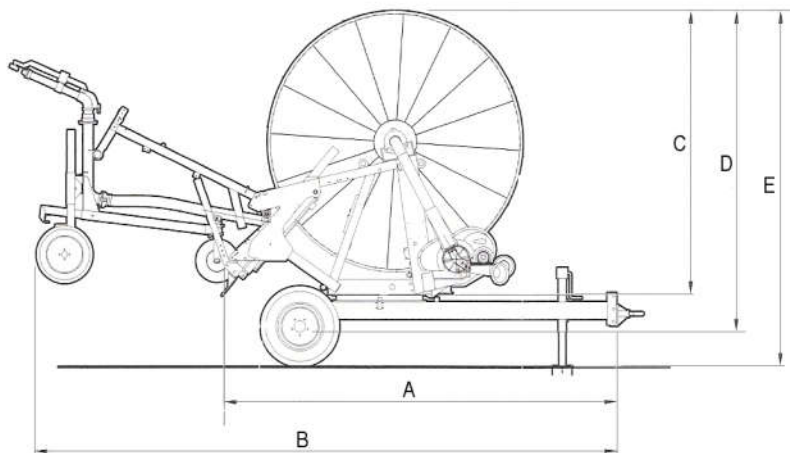

A & B – Dimensions include towing eye

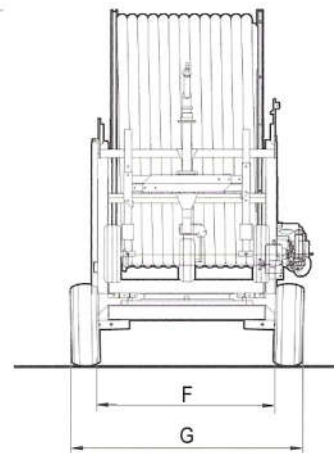

F & G – Dimensions include drive system

Dimensions

A	13'-0"
B	17'-6"
C	9'-0"
D	10'-3"
E	11'-0"
F	7'-7"
G	8'-8"

Empty Weight

6,500 lbs