

Standard Features

- Turbine driven for irrigation or wastewater.
- Turbine and gearbox assembly no belts or pulleys.
- 4-Speed gearbox for high-speed light applications.
- PTO Wind-in.
- Automatic speed compensation.
- Digital Rainstar 060 tachometer with solar panel.
- Pressure gauge
- Adjustable width galvanized cart.
- Automatic cart lifting.
- 12-foot heavy-duty rubber supply hose.
- Supply hose adapter (female bauer).
- Galvanized chassis, drum and frame.
- Hydraulically operated galvanized stabilizer legs.
- 360 degree rotation turntable.

P.E. Pipe O.D.: 4.9" (125 mm)			P.E. Pipe I.D.: 4.0" (102 mm)				P.E. Pipe Length: 820' (250 m)								
125 gx 820 							SPEED OF P.E. PIPE PULL IN METERS/HOUR								
							15	20	25	30	40	50	60	100	
SPRINKLER: KOMET TWIN 202 ULTRA							SPEED OF P.E. PIPE PULL IN FEET/HOUR								
							50	65	80	100	130	165	195	325	
INLET PRESSURE (PSI)	NOZZLE PRESSURE (PSI)	NOZZLE SIZE (MM)	WATER FLOW (GPM)	SPRAY RANGE (FEET)	SPACING (FEET) 85%	ACRES PER PULL	PRECIPITATION RATE IN INCHES								
76	60	28 (1.10)	272	173	300	6.7	1.6	1.3	1.0	0.8	0.6	0.5	0.4	0.3	
89	70		294	182	300	6.7	1.8	1.4	1.1	0.9	0.7	0.5	0.4	0.3	
103	80		314	190	300	6.8	1.9	1.5	1.2	0.9	0.7	0.6	0.5	0.3	
83	60	30 (1.18)	312	178	300	6.7	2.0	1.5	1.2	1.0	0.8	0.6	0.5	0.3	
97	70		337	190	330	7.4	1.9	1.5	1.2	0.9	0.7	0.6	0.5	0.3	
110	80		360	198	330	7.5	2.0	1.6	1.3	1.0	0.8	0.6	0.5	0.3	
91	60	32 (1.26)	357	184	330	7.4	2.1	1.6	1.3	1.0	0.8	0.6	0.5	0.3	
103	70		386	197	330	7.5	2.2	1.7	1.4	1.1	0.9	0.7	0.6	0.3	
116	80		412	206	330	7.5	2.4	1.9	1.5	1.2	0.9	0.7	0.6	0.4	
97	60	34 (1.34)	400	190	330	7.4	2.4	1.9	1.5	1.2	0.9	0.7	0.6	0.4	
106	70		433	204	360	8.2	2.2	1.7	1.4	1.1	0.8	0.7	0.6	0.4	
121	80		462	213	360	8.3	2.6	2.0	1.6	1.3	1.0	0.8	0.7	0.4	
108	60	38 (1.50)	501	203	360	8.2	2.5	2.0	1.6	1.3	1.0	0.8	0.7	0.4	
122	70		541	217	360	8.3	2.7	2.5	1.8	1.4	1.1	0.9	0.7	0.4	
137	80		579	228	360	8.4	2.9	2.3	1.8	1.5	1.1	0.9	0.8	0.5	
ESTIMATED TIME FOR COMPLETE WINDING IN HOURS → → →							16.5	12.5	10.0	8.0	6.5	5.0	4.0	2.5	

Performance data has been obtained under ideal test conditions and may be adversely affected by wind, poor inlet pressure conditions or other factors.

No representation regarding droplet condition, uniformity, application rate or suitability for a particular application is made herein.

Operating at lower or higher pressures than stated above may result in warranty being voided.

Acreage is based on 1-inch application, 15 hours a day, 7 days a week.

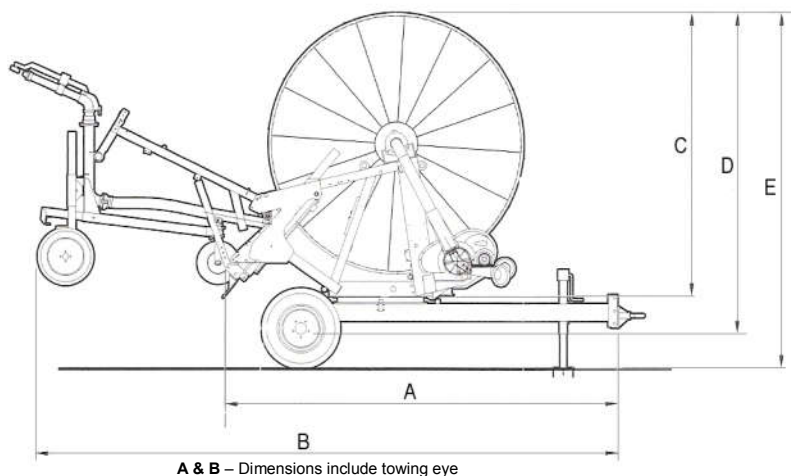

A & B – Dimensions include towing eye

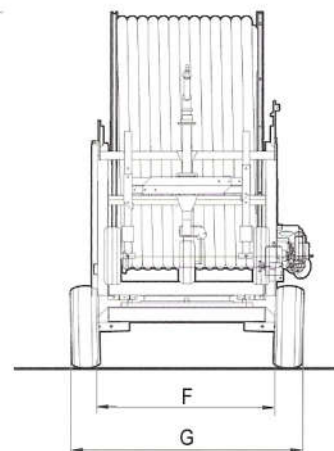

F & G – Dimensions include drive system

Dimensions

A	13'-0"
B	17'-6"
C	9'-0"
D	10'-3"
E	11'-0"
F	7'-7"
G	8'-8"

Empty Weight

6,500 lbs