

## Standard Features

- Turbine driven for irrigation or wastewater.
- Turbine and gearbox assembly no belts or pulleys.
- 4-Speed gearbox for high-speed light applications.
- PTO Wind-in.
- Automatic speed compensation.
- Digital Rainstar 060 tachometer with solar panel.
- Pressure gauge
- Adjustable width galvanized cart.
- Manual cart lifting.
- 12-foot heavy-duty rubber supply hose.
- Supply hose adapter (female bauer).
- Galvanized chassis, drum and frame.
- Mechanical operated galvanized stabilizer legs.
- 360 degree rotation turntable.

P.E. Pipe O.D.: 2.5" (63 mm)			P.E. Pipe I.D.: 2.1" (53 mm)				P.E. Pipe Length: 985' (300 m)								
<b>63 gx 985</b>							SPEED OF P.E. PIPE PULL IN METERS/HOUR								
							15	20	25	30	40	50	60	100	
SPRINKLER: KOMET TWIN 101 ULTRA							SPEED OF P.E. PIPE PULL IN FEET/HOUR								
							50	65	80	100	130	165	195	325	
INLET PRESSURE (PSI)	NOZZLE PRESSURE (PSI)	NOZZLE SIZE (MM)	WATER FLOW (GPM)	SPRAY RANGE (FEET)	SPACING (FEET) 85%	ACRES PER PULL	PRECIPITATION RATE IN INCHES								
76	50	12 (0.47)	45	106	180	4.4	0.5	0.4	0.3	0.3	0.2	0.2	0.1	0.1	
89	60		50	109	180	4.4	0.5	0.4	0.3	0.3	0.2	0.2	0.1	0.1	
100	70		54	114	180	4.5	0.6	0.4	0.4	0.3	0.2	0.2	0.1	0.1	
83	50	14 (0.55)	62	112	180	4.4	0.7	0.5	0.4	0.3	0.3	0.2	0.2	0.1	
95	60		67	117	180	4.5	0.7	0.5	0.4	0.4	0.3	0.2	0.2	0.1	
112	70		73	121	180	4.5	0.8	0.6	0.4	0.4	0.3	0.2	0.2	0.1	
98	50	16 (0.63)	80	118	180	4.5	0.9	0.7	0.5	0.4	0.3	0.3	0.2	0.1	
116	60		87	123	210	5.2	0.8	0.6	0.5	0.4	0.3	0.3	0.2	0.1	
132	70		94	129	210	5.3	0.9	0.7	0.5	0.4	0.3	0.3	0.2	0.1	
119	50	18 (0.71)	101	123	210	5.2	0.9	0.7	0.5	0.4	0.3	0.3	0.2	0.1	
137	60		111	131	210	5.3	1.0	0.8	0.5	0.4	0.3	0.3	0.2	0.2	
155	70		119	137	210	5.3	1.1	0.8	0.6	0.5	0.4	0.3	0.2	0.2	
140	50	20 (0.79)	125	129	210	5.3	1.3	1.0	0.8	0.6	0.5	0.4	0.3	0.2	
158	60		137	138	240	6.0	1.3	1.0	0.8	0.6	0.5	0.4	0.3	0.2	
ESTIMATED TIME FOR COMPLETE WINDING IN HOURS → → →							19.5	15.0	12.0	9.5	7.5	6.0	5.0	3.0	

Performance data has been obtained under ideal test conditions and may be adversely affected by wind, poor inlet pressure conditions or other factors.

No representation regarding droplet condition, uniformity, application rate or suitability for a particular application is made herein.

Operating at lower or higher pressures than stated above may result in warranty being voided.

Acreage is based on 1-inch application, 15 hours a day, 7 days a week.

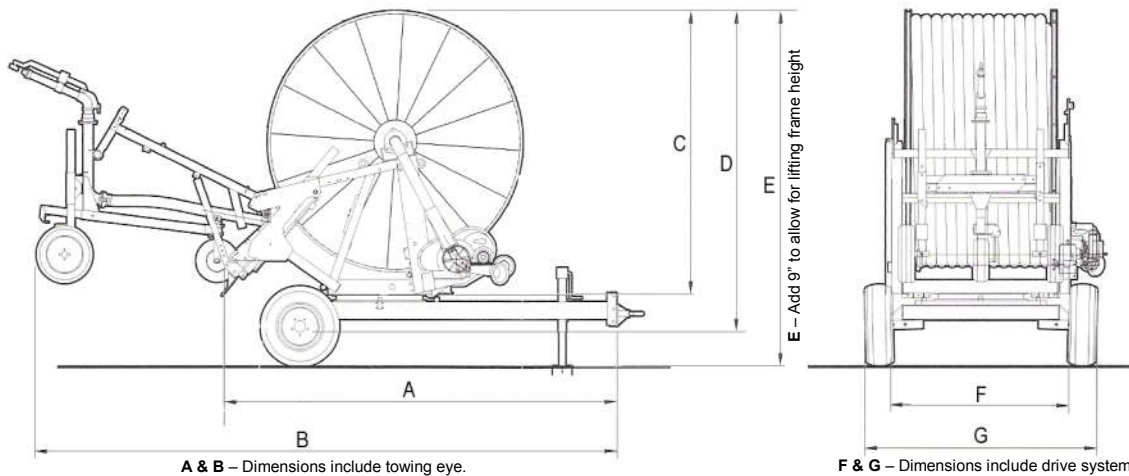

### Dimensions

A	9'-11"
B	15'-0"
C	6'-1"
D	6'-11"
E	7'-8"
F	5'-6"
G	6'-0"

### Empty Weight

2,600 lbs