

Standard Features

- Turbine driven for irrigation or wastewater.
- Turbine and gearbox assembly no belts or pulleys.
- 4-Speed gearbox for high-speed light applications.
- PTO Wind-in.
- Automatic speed compensation.
- Digital Rainstar 060 tachometer with solar panel.
- Pressure gauge
- Adjustable width galvanized cart.
- Manual cart lifting.
- 12-foot heavy-duty rubber supply hose.
- Supply hose adapter (female bauer).
- Galvanized chassis, drum and frame.
- Mechanical operated galvanized stabilizer legs.
- 360 degree rotation turntable.

P.E. Pipe O.D.: 3.2" (82 mm)			P.E. Pipe I.D.: 2.7" (68.5 mm)				P.E. Pipe Length: 525' (160 m)							
82 gx 525							SPEED OF P.E. PIPE PULL IN METERS/HOUR							
							15	20	25	30	40	50	60	100
SPRINKLER: KOMET TWIN 101 ULTRA							SPEED OF P.E. PIPE PULL IN FEET/HOUR							
							50	65	80	100	130	165	195	325
INLET PRESSURE (PSI)	NOZZLE PRESSURE (PSI)	NOZZLE SIZE (MM)	WATER FLOW (GPM)	SPRAY RANGE (FEET)	SPACING (FEET) 85%	ACRES PER PULL	PRECIPITATION RATE IN INCHES							
62	50	16 (0.63)	80	117	180	2.5	0.9	0.7	0.5	0.4	0.3	0.3	0.2	0.1
74	60		87	123	210	3.0	0.8	0.6	0.5	0.4	0.3	0.3	0.2	0.1
85	70		94	129	210	3.0	0.9	0.7	0.5	0.4	0.3	0.3	0.2	0.1
66	50	18 (0.71)	101	123	210	3.0	0.9	0.7	0.5	0.4	0.3	0.3	0.2	0.1
78	60		111	131	210	3.1	1.0	0.8	0.5	0.4	0.3	0.3	0.2	0.2
90	70		119	137	210	3.1	1.1	0.8	0.6	0.5	0.4	0.3	0.2	0.2
71	50	20 (0.79)	125	129	210	3.1	1.1	0.9	0.7	0.6	0.4	0.3	0.3	0.2
82	60		137	138	240	3.5	1.1	0.9	0.7	0.6	0.4	0.3	0.3	0.2
95	70		148	145	240	3.6	1.2	0.9	0.7	0.6	0.5	0.4	0.3	0.2
76	50	22 (0.87)	151	135	240	3.5	1.2	0.9	0.7	0.6	0.5	0.4	0.3	0.2
90	60		165	144	240	3.6	1.3	1.0	0.8	0.7	0.5	0.4	0.3	0.2
102	70		178	152	240	3.6	1.4	1.1	0.8	0.7	0.5	0.4	0.3	0.2
83	50	24 (0.94)	180	140	240	3.6	1.5	1.1	0.9	0.7	0.6	0.4	0.4	0.2
97	60		197	151	270	4.0	1.4	1.1	0.9	0.7	0.6	0.5	0.4	0.2
112	70		212	160	270	4.1	1.5	1.2	1.0	0.8	0.6	0.5	0.4	0.2
ESTIMATED TIME FOR COMPLETE WINDING IN HOURS → → →							10.5	8.0	6.5	5.0	4.0	3.0	2.5	1.5

Performance data has been obtained under ideal test conditions and may be adversely affected by wind, poor inlet pressure conditions or other factors.

No representation regarding droplet condition, uniformity, application rate or suitability for a particular application is made herein.

Operating at lower or higher pressures than stated above may result in warranty being voided.

Acreage is based on 1-inch application, 15 hours a day, 7 days a week.

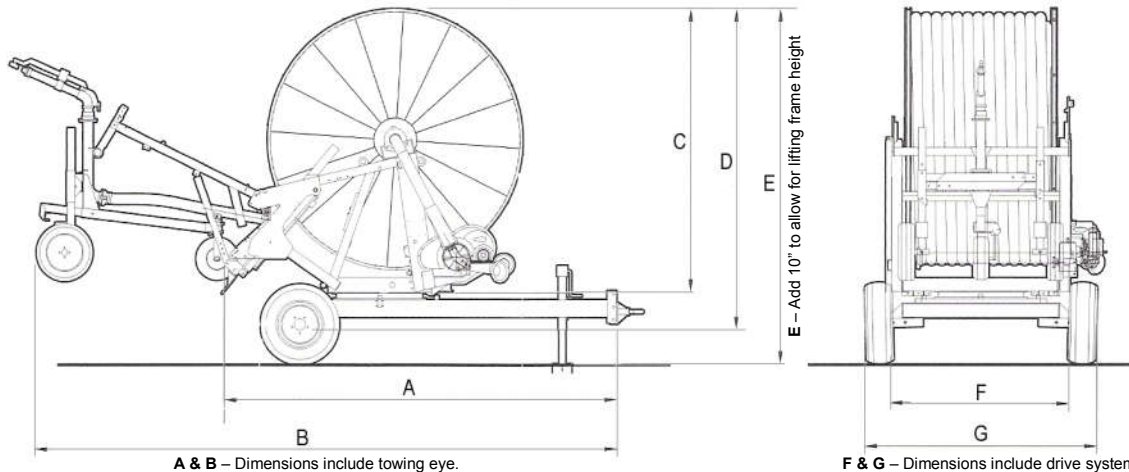

Dimensions

A	9'-11"
B	15'-0"
C	6'-1"
D	6'-11"
E	7'-8"
F	5'-6"
G	6'-0"

Empty Weight

2,600 lbs