

## Standard Features

- Turbine driven for irrigation or wastewater.
- Turbine and gearbox assembly no belts or pulleys.
- 4-Speed gearbox for high-speed light applications.
- PTO Wind-in.
- Automatic speed compensation.
- Digital Rainstar 060 tachometer with solar panel.
- Pressure gauge
- Adjustable width galvanized cart.
- Automatic cart lifting.
- 12-foot heavy-duty rubber supply hose.
- Supply hose adapter (female bauer).
- Galvanized chassis, drum and frame.
- Hydraulically operated galvanized stabilizer legs.
- 360 degree rotation turntable.

P.E. Pipe O.D.: 3.2" (82 mm)			P.E. Pipe I.D.: 2.7" (68.5 mm)				P.E. Pipe Length: 985' (300 m)								
82 gx 985							SPEED OF P.E. PIPE PULL IN METERS/HOUR								
							15	20	25	30	40	50	60	100	
SPRINKLER: KOMET TWIN 101 ULTRA							SPEED OF P.E. PIPE PULL IN FEET/HOUR								
							50	65	80	100	130	165	195	325	
INLET PRESSURE (PSI)	NOZZLE PRESSURE (PSI)	NOZZLE SIZE (MM)	WATER FLOW (GPM)	SPRAY RANGE (FEET)	SPACING (FEET) 85%	ACRES PER PULL	PRECIPITATION RATE IN INCHES								
68	50	16 (0.63)	80	117	180	4.5	0.9	0.7	0.5	0.4	0.3	0.3	0.2	0.1	
82	60		87	123	210	5.2	0.8	0.6	0.5	0.4	0.3	0.3	0.2	0.1	
93	70		94	129	210	5.2	0.9	0.7	0.5	0.4	0.3	0.3	0.2	0.1	
76	50	18 (0.71)	101	123	210	5.2	0.9	0.7	0.5	0.4	0.3	0.3	0.2	0.1	
91	60		111	131	210	5.3	1.0	0.8	0.5	0.4	0.3	0.3	0.2	0.2	
105	70		119	137	210	5.3	1.1	0.8	0.6	0.5	0.4	0.3	0.2	0.2	
86	50	20 (0.79)	125	129	210	5.3	1.1	0.9	0.7	0.6	0.4	0.3	0.3	0.2	
100	60		137	138	240	6.0	1.1	0.9	0.7	0.6	0.4	0.3	0.3	0.2	
117	70		148	145	240	6.1	1.2	0.9	0.7	0.6	0.5	0.4	0.3	0.2	
98	50	22 (0.87)	151	135	240	6.0	1.2	0.9	0.7	0.6	0.5	0.4	0.3	0.2	
109	60		165	144	240	6.1	1.3	1.0	0.8	0.7	0.5	0.4	0.3	0.2	
130	70		178	152	240	6.1	1.4	1.1	0.8	0.7	0.5	0.4	0.3	0.2	
111	50	24 (0.94)	180	140	240	6.0	1.5	1.1	0.9	0.7	0.6	0.4	0.4	0.2	
129	60		197	151	270	6.9	1.4	1.1	0.9	0.7	0.6	0.5	0.4	0.2	
149	70		212	160	270	6.9	1.5	1.2	1.0	0.8	0.6	0.5	0.4	0.2	
ESTIMATED TIME FOR COMPLETE WINDING IN HOURS → → →							19.5	15.0	12.0	9.5	7.5	6.0	5.0	3.0	

Performance data has been obtained under ideal test conditions and may be adversely affected by wind, poor inlet pressure conditions or other factors.

No representation regarding droplet condition, uniformity, application rate or suitability for a particular application is made herein.

Operating at lower or higher pressures than stated above may result in warranty being voided.

Acreage is based on 1-inch application, 15 hours a day, 7 days a week.

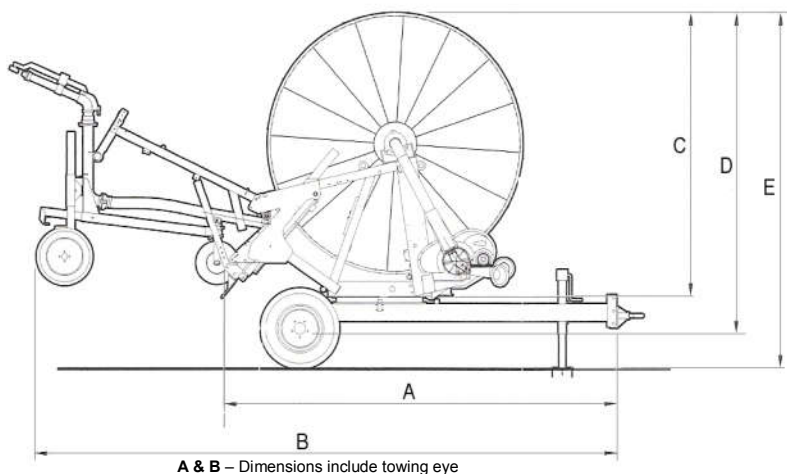

A & B – Dimensions include towing eye

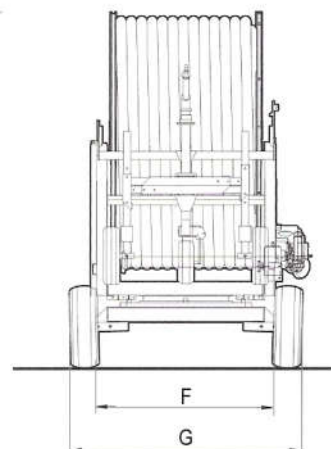

F & G – Dimensions include drive system

### Dimensions

A	11'-8"
B	16'-6"
C	6'-9"
D	7'-10"
E	8'-9"
F	7'-8"
G	7'-8"

### Empty Weight

3,800 lbs