

SERIES 690 GX (d.690592)



POS.	Page	Description	N.Pieces	Item Number	Notes
1	11	Plug Ø 108 Bauer	1	8900112	
2	11	Rubber Ring Ø 108 Bauer	2	5801142	
3	11	Crossover Pipe Ø 108 Bauer	1	6001054	
4	11	Hosetail Coupler Bauer Ø 108 Male zinc	2	5801138	
5	11	Clamp 110	4	5800139	
6	11	Rubber Hose 102x114	1	5800113	4.5 meters
7	11	Key 5x9	1	8900205	
8	11	Bolt TE M8x25 zinc	12	8900204	
9	11	Turbine Flange	1	5810018	
10	11	O-Ring 4850 (turbing cover)	1	5500102	
11	11	Washer 1/16"	4	8900202	
12	11	Bolt TCEI M8x20	4	8900203	
13	11	Mechanical Seal BT PR/FN 20 L	1	8900201	
14	11	Impeller	1	5500003	
15	11	Impeller Nut M16x1,5 S.S.	1	5800209	
16	11	Turbine Body 150 degree	1	5501002	
17	11	Nozzle	1	5500202	Ø ...
18	11	Gasket	1	5500004	
19	11	O-Ring 108	2	5800213	
20	11	Nut M5 S.S.	2	5800211	
21	11	Flapper	1	5500007	
22	11	By-Pass Valve Shaft	1	5500006	
23	11	Rollpin Ø 5	1	5800212	
24	11	Bolt TCEI M5x20 S.S.	2	5800210	
25	11	By-Pass Lever	1	8900040	
26	11	By-Pass Stop	1	5800030	
27	11	Threaded Knob	1	5800102	
28					
29	11	Rubber Grip 25x10	2	5800109	
30	11	Turbine Cover	1	6000077	
31	11	Pressure Gauge GJ 1/4	1	5800115	
32	11	Clamp 86-95	4	5800137	
33	11	Rubber Hose 80x92	1	5500102	.35 meters
34	11	By-Pass Rod	1	6002025	
35	11	Inlet Flange x Hosetail	1	6001014	c.36+37
36	11	Gasket	1		c.35+37
37	11	Inlet Elbow with Flange	1		c.35+36
38	11	Cap 3" FBSP	1	8000121	
39	11	Gease Zirk M6	3	5800112	
40	11	Ring UM 100-120-10	2	7001106	
		Flange	1	6000068	
		O-Ring 210 for flange	1	9000118	
41	11	Circlip E 100	1	7000110	
42	11	Bearing 6220	1	7000108	
43	11	Bearing support	1	7000003	
44	11	Shaft Sleeve S.S.	1	7000054	
45	11	O-Ring 2375 (shaft sleeve)	1	7000117	

SERIES 690 GX (d.690592)



POS.	Page	Description	N.Pieces	Item Number	Notes
46	11	Reel Complete Ø internal 1340	1	6002002	
47	11	Drum Tooth M16x60 with nut	12	7000036	
48	11	Clamp PE Ø 90 (86-95)	3	5800137	
		Clamp PE Ø 100 (90-105)	3	5900102	
		Clamp PE Ø 110 (105-115)	3	5800114	
		Clamp PE Ø 120 (115-130)	3	8000120	
49	11	PET Hose Coupler	1	5500033	Ø PE...
50	11	PET Hose (specify size and length)	1	TUBPOL...	ml...
51	11	Shut-Off Cable	1	5500041	
52	11	By-Pass Stop	1	5800058	
53	11	Spring	1	8900048	
54	11	Overwind Bar Complete	1	6001020	
55	11	Reel Side Cover	2	70010012	
56	11	Bearing UCP 210	1	7000111	
57	11	Circlip E50	1	7000109	
58	11	Sprocket 1/2" S	2	5500037	z...
59	11	Cursor	1	5801006	
60	11	Cursor Finger	1	5800050	
61	11	Circlip I35	1	5800144	
62	11	Gease Zirk M6	1	5800112	
63	11	Level Guide Bar	1	5900005	
64	11	Bearing UCPA 206	2	6000104	
65	11	Master Link 1/2" S	1	5800120	
66	11	Chain 1/2" S	1	5800119	3.2 meters
67	11	Primary Chain Cover (back)	2	5700028	
68	11	Primary Chain Cover	1	7000037	
69	11	(see pos. 134)			
70	11	Lifting Frame Shut-Off Bar	1	6001040	
71	11	Lifting Frame	1	6002039	
72	11				
74	11	Hoseguide Forks	1	6000011	
75	11	Hydraulic Distributor (4 lever)	1	7000303	op
76	11	R-Clip Ø 4	4		
77	11	Hoseguide Roller Axle	1	5900007	
78	11	Hoseguide Roller PVC	1	6000043	
79	11	Lifting Frame Guide (upper)	2	6000041	
80	11	Lifting Frame Guide (lower)	2	6000042	
81	11				
82	11				
83	11				
84	11				
85	11	Hydraulic Foot	2	6000032	
		Right Foot (mechanical)	1	6000012	op
		Left Foot (mechanical)	1	6000012	op
86	11	Hydraulic Cylinder	2	6000033	
87	11	Nipple 3/8" - 1/4"	4	7000307	

SERIES 690 GX (d.690592)



POS.	Page	Description	N.Pieces	Item Number	Notes
88	11	Copper Washer 3/8"	4		
89	11	Hydraulic Hose 1/4" L=1800	4	8900110	
90	11	Terret Frame version 2004	1	6002003	
91	11	P.T.O. Handle	1	5800041	
92	11	Anti-Return Pawl Complete	1	7900011+7900012	
93	11	Spring	1	5500040	
94	11	(see pos. 129)			
95	11	(see pos. 129)			
96	11	Idler Sprocket Shaft	1	8900012	
97	11	Idler Sprocket 1" Z10	1	8900027	
98	11	Idler Bracket	1	6000066	
99	11	(see pos. 98)			
100	11	U-Bolt	1	8900106	
101	11	Crossover Support	1	8900019	
102	11	Hydraulic Distributor (3 lever)	1	7000302	op
103	11	Hydraulic Distributor (2 lever)	1	7000301	op
104	11	Hydraulic Hose 1/4" L=1300	2	7000313	op
105	11	Hydraulic Hose 1/4" L=10000	2	7000312	
106	11	Tractor Coupler M	2	7000309	
107	11	Nipple 1/4"-1/2"	2	7000308	
108	11	Nipple 1/4"-3/8"	2	7000307	op
109	11	Nipple 3/8"-1/4"	8	7000307	op
110	11	Hydraulic Hose 1/4" L=2300	2	6000114	op
111	11	Hydraulic Hose 1/4" L=5000	2	9000112	op
112	11	Hydraulic Chassis Jack	1	6000030	op
		Mechanical Chassis Jack	1	6000017	
113	11	Coupler	1	5500042	op
114	11	Hydraulic Motor Mounting Bracket	1	9900033	op
115	11	Sprocket Z13 M7	3	7000403	op
116	11	Hydraulic Motor GFL300	1	7000304	op
117	11	Turntable Bearing U01P090	1	5900101	
118	11	Turntable Gear	1	7000402	op
119	11	Towing Eye Pin	2	7000032	
120	11	R-Clip Ø 5	2	COOP05AMA	
121	11	Towing Eye	1	7000031	
		Towing Eye omologato	1	7001031	op
122	11	Chassis	1	6001034	
123	11	T-Coupler 1/4"	2	6000111	
124	11	Hydraulic Hose Bracket	8	7000047	
125	11	Tachometer Complete	1	TACHVDOSPRINT	v.pag.22
126	11	Drive Sprocket Washer	1	7000072	
127	11	Drive Sprocket 1" S Z11 Ø32	1	6000065	
128	11	Spacer 1"	1	6000076	
129	11	Gearbox Comer D 745 A	1	5810101	v.pag.16/1
130	11	Brake Pad	1	5800143	i2.744.7006.00
131	11	Oil Plug	1		i8.6.7.00269
132	11	Coupler Ø 108 F	1	5801136	gr

SERIES 690 GX (d.690592)



POS.	Page	Description	N.Pieces	Item Number	Notes
133	11	Gearbox Speed Lever	1	6000075	
134	11	Gearbox Shut-Off Cable	1	5500025	
135	11	Master Link catena 1"	1	7000104	
136	11				
137	11				
138	11				
139	11				
140	11				
141	11				
142	11				
143	11	Single Axle Assembly	2	5800117	
144	11	Spindle Lug Nut Stud	10	5800153	
145	11	Wheel 10.0/75-15.3 10 ply 5 lug	2	6000101	
		Wheel 31x15.50-15 8ply	2	6000113	op
146	11	Lug Nut M18	10	5800154	
147	11	Hydraulic Hose 1/4" L=2600	2	7000311	
148	11	Chain 1" FKK	1	7000103	7.8 meters
149	11	Turntable Locking Pin	1	5800043	
150	11	Boom Lifting Frame	1	6000044	op
151	11	Boom Lifting Frame Fork	1	5800068	op
152	11	Mounting Bracket	4	5800069	op
153	11	Chain	2	060106	1 meter
154	11	Hydraulic Cylinder	2	6000055	op
155	11	Boom Shut-Off Bar	1	6001045	op
156	11	Nipple 3/8"-1/4"	4	7000307	op
157	11	Hydraulic Hose 1/4" L=1320	4	6000109	op
158	11	T-Coupler 1/4"	2	6000111	op
159	11	Nipple 3/8"-1/4"	2	7000307	op
7					
8					
9					
10					
11					
12					
13					
14					
15					
16	11	Turbine Complete T2M	1	TUR550M	
17					
18					
19					
20					
21					
22					
23					
24					

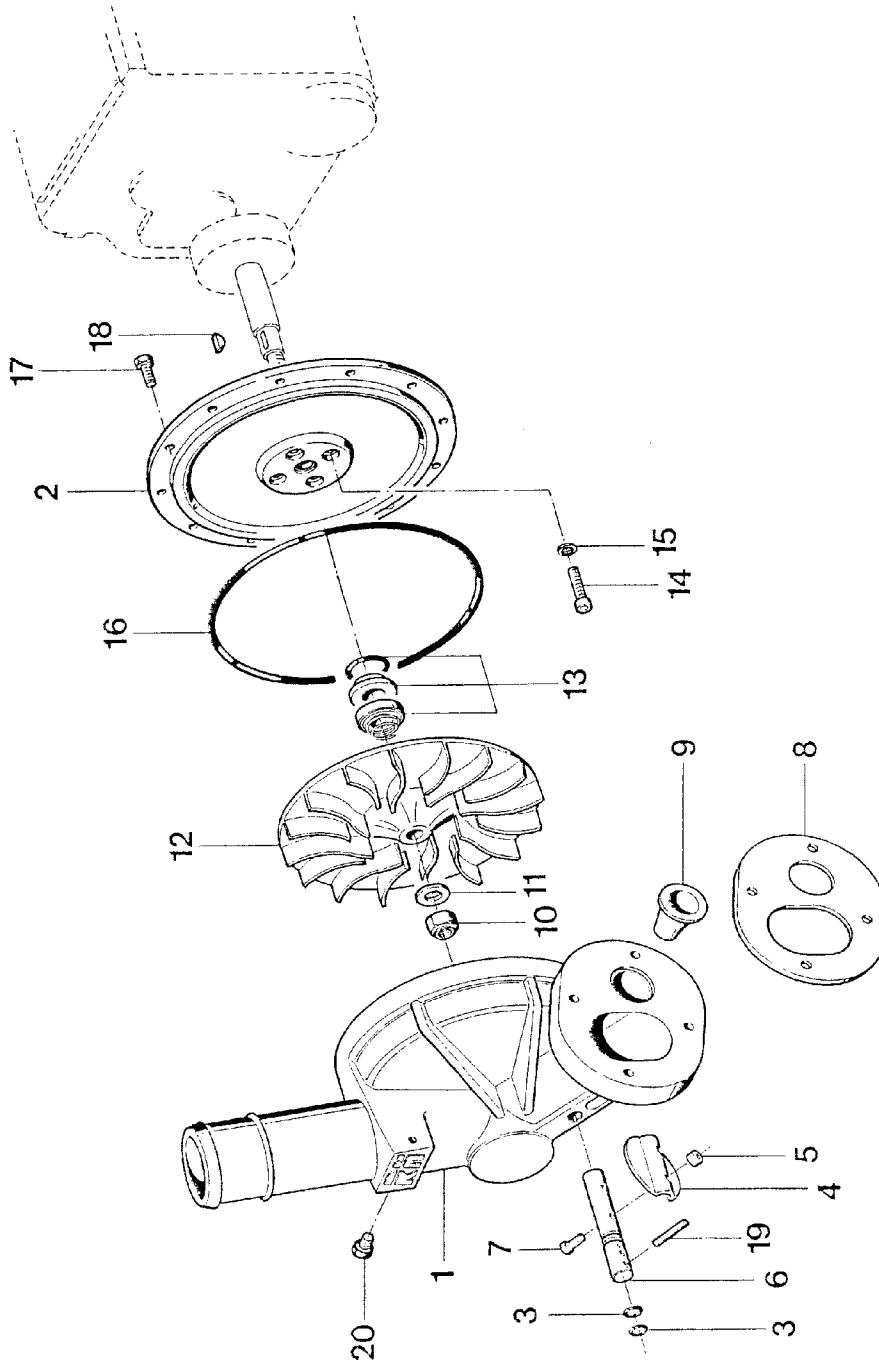

TURBINE T2M



POS.	Page	Description	N.Pieces	Item Number	Notes
1	13/1	Turbine Body 150 degree	1	5501002	
2	13/1	Turbine Flange T2M	1	5810018	
3	13/1	O-Ring 108	2	5800213	
4	13/1	Flapper	1	5500007	
5	13/1	Nut S.S. M5	2	5800211	
6	13/1	By-Pass Valve Shaft	1	5500006	
7	13/1	Bolt TE M5x20 S.S.	2	5800210	
8	13/1	Gasket	1	5500004	
9	13/1	Nozzle Mizar	1	5500202	Ø ...
10	13/1	Nut/Nylock M16 S.S.	1	5800209	
11	13/1	Washer S.S. 17x30x3	1	5800218	
12	13/1	Impeller	1	5500003	
13	13/1	Mechanical Seal Ø20	1	8900201	
14	13/1	Bolt TCEI M8x20 S.S.	4	8900203	
15	13/1	Copper Washer 8x14	4	8900202	
16	13/1	O-Ring 4850	1	5500102	
17	13/1	Bolt TE M8x25	8	8900204	
18	13/1	Woodruff Key 5x9	1	8900205	
19	13/1	Rollpin 5x25	1	5800212	
20	13/1	Plug 1/4" zinc	1	5800208	

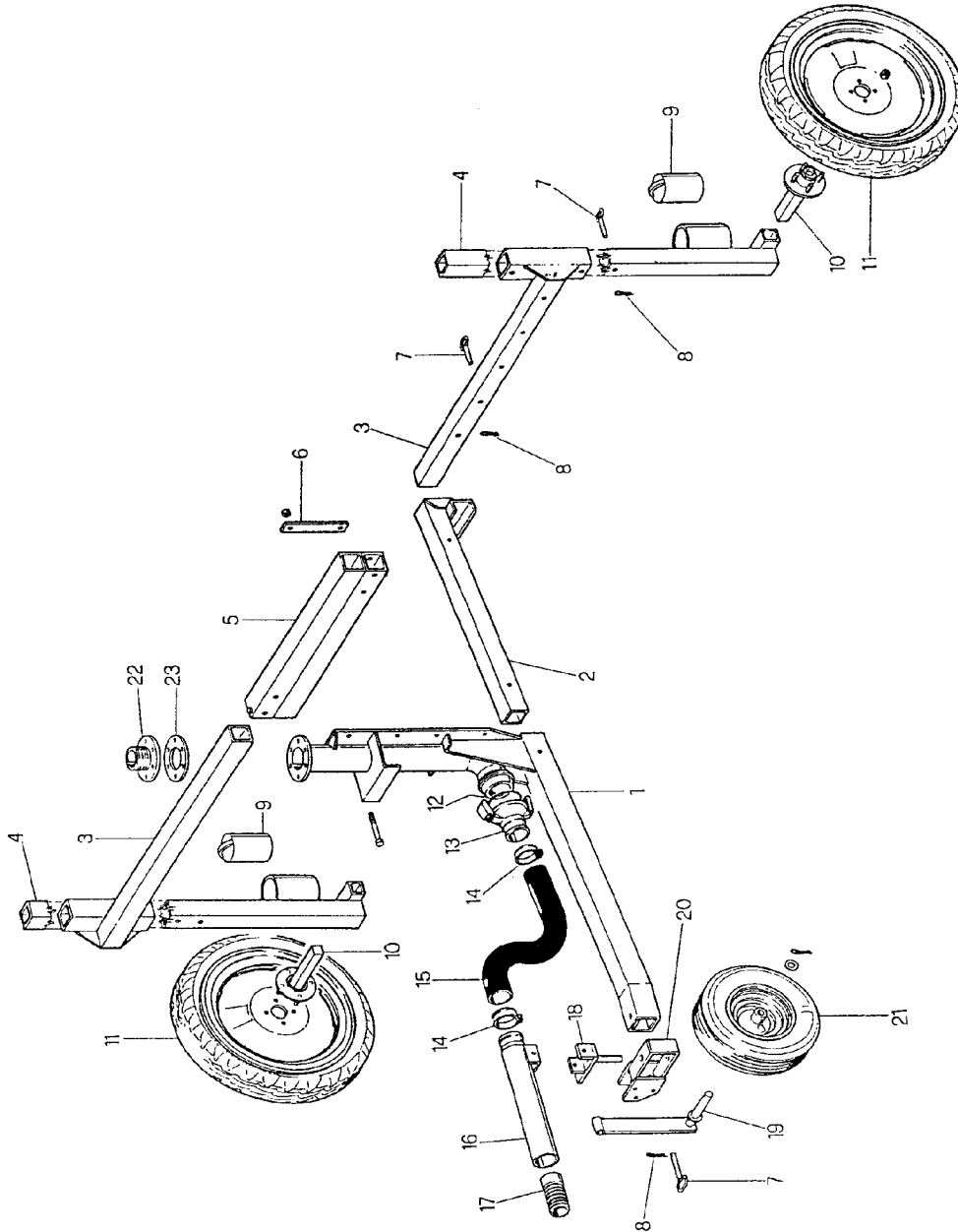

SERIES 580-600 GX TROLLEY (VERSION '98)



POS.	Page	Description	N.Pieces	Item Number	Notes
1	28	Trolley Body	1	58020189	
2	28	Drawbar	1	580201810	
3	28	Leg Support	2	58020185	
4	28	Leg	2	58020186	
5	28	Head	1	58020184	
6	28	Head Mounting Bracket	2	58020181	
7	28	Pin	5	5800042	
8	28	R-Clip Ø 3	5	COOP03AMA	
9	28	Weight	2	BILLETTE	.3 meters
10	28	Hub Assembly 4 lug 35 L=200	2	5800103	
11	28	Wheel 125/70 D15	2	5800104	pn
12	28	Rubber Ring Ø 80 Ferrari	1		c.13
13	28	Coupler Ø 80 with Rubber Ring	1	580201811	c.12
14	28	Clamp 86-95	2	5800137	
15	28	Rubber Hose 10 80 x 93	1	5500102	1.1 meters
16	28	Attachment PE-Trolley	1	58020188	
17	28	Barbed Nipple PE	1	5500033	gr - Ø PE
18	28	Pivot Pin	1	58020187	
19	28	Wheel Support	1	58020183	
20	28	Wheel pivot Bracket	1	58020182	
21	28	Wheel 5.00 x 8"	1	5800149	
22	28	Coupler for Ranger	1	5800044	Ø PE -100-
		Coupler for Sinkro	1	5700039	110
23	28	Gasket	1	58000461	Ø PE 82
1		- - - - - Trolley Bare 580-600GX - - - - -			
2					
3					
4					
5					
6	28			1	5802018
13					
16					
18					
19					
20					
1÷21	28	Trolley Complete	1	CARR5803	

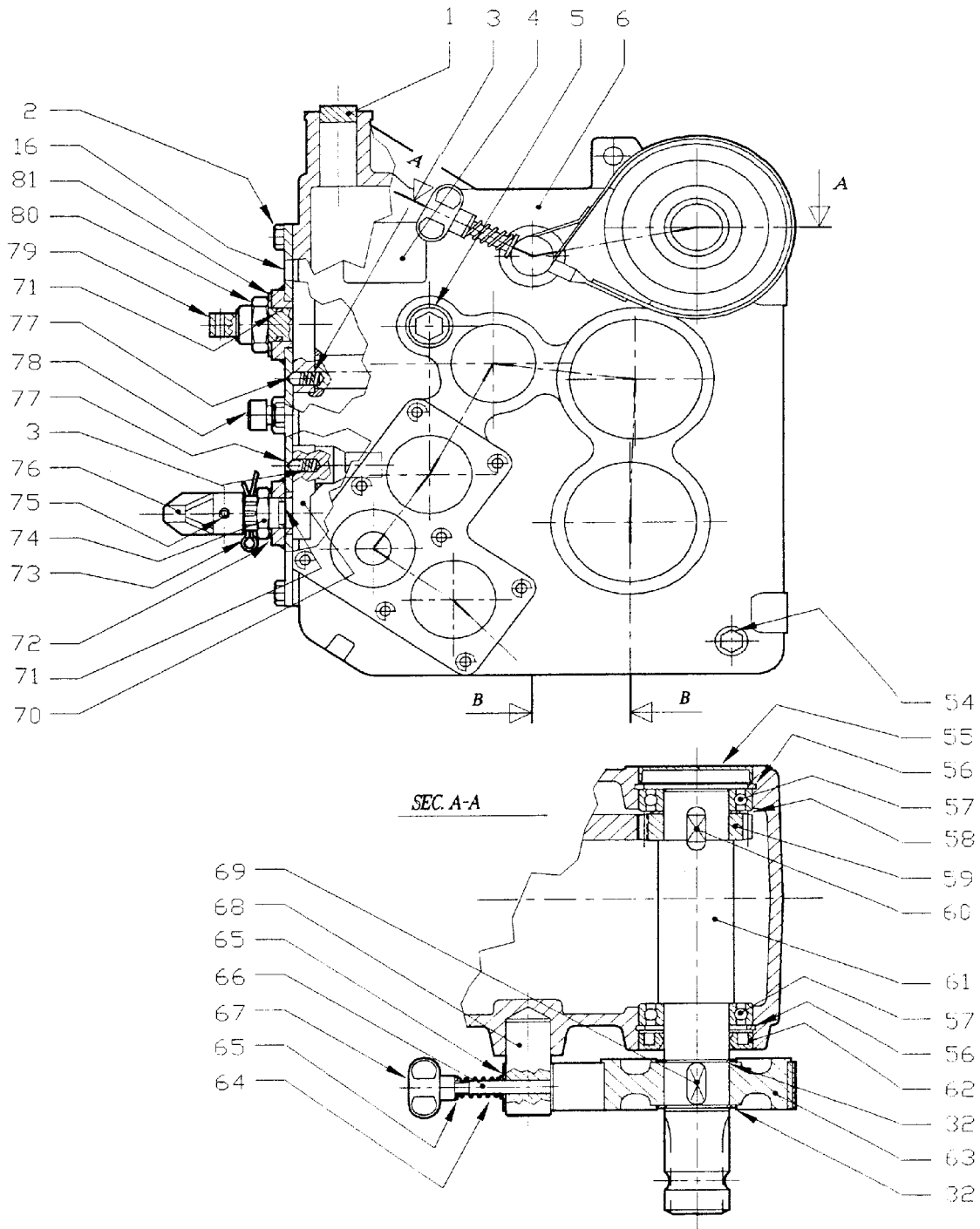

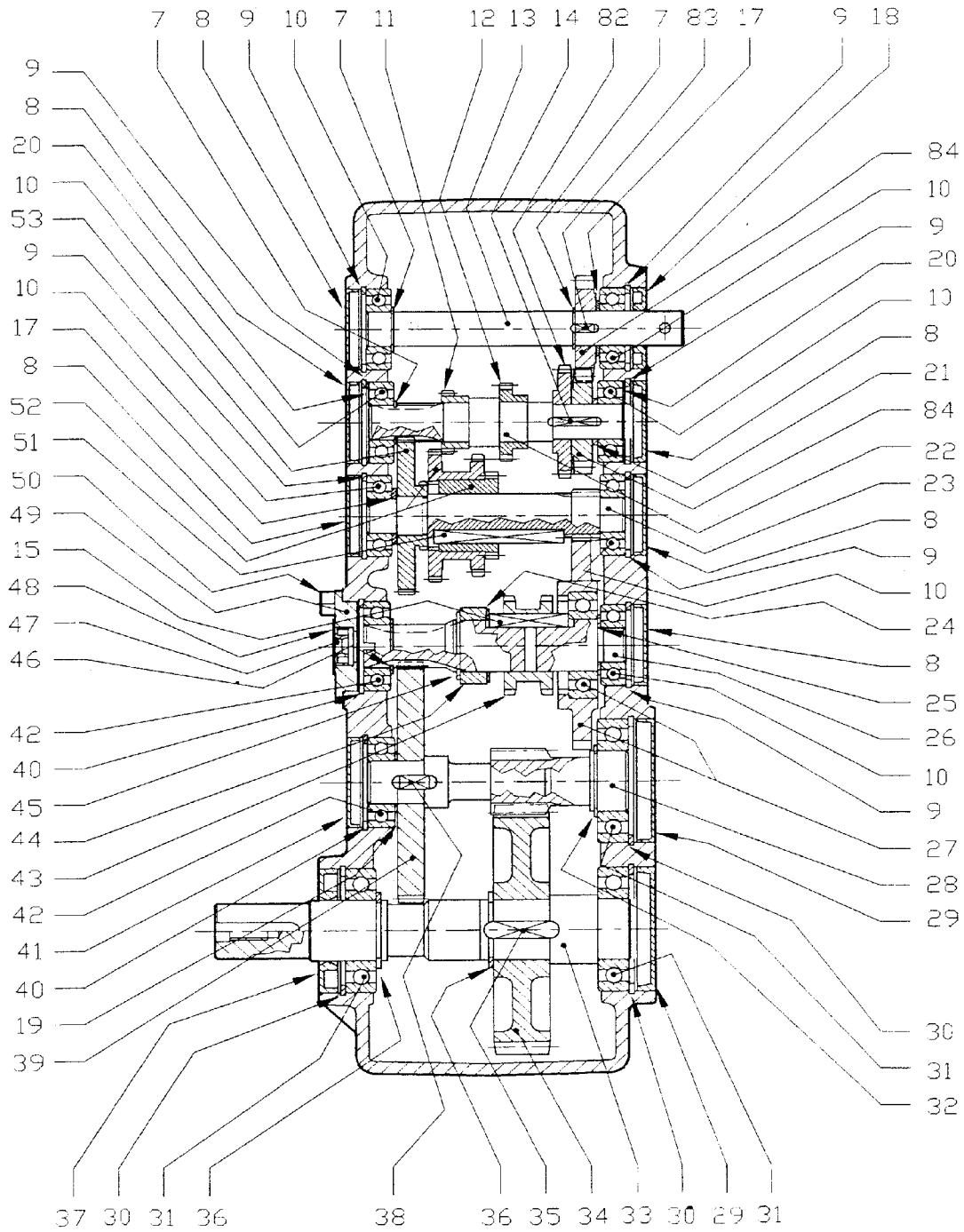

GEARBOX D-745A (9.745.044.00)



POS.	Page	Description	N.Pieces	Item Number	Notes
1	16/1	Plug	1	01202.069.041	
2	16/1	Bolt TE M8x18 (8.8)	6	8.1.1.01676	
3	16/1	Spring	2	0.721.7101.00	
4	16/1	Serial Plate "COMER"	1	0.124.7101.00	
5	16/1	Oil Sight Glass	1	8.6.4.00273	
6	16/1	Casing	1	0.745.0300.00	
7	16/1	Circlip E20	3	8.5.1.00261	
8	16/1	Oil Plug 47x7	6	8.7.0.01362	9510576000
9	16/1	Circlip I47	7	8.5.2.01290	
10	16/1	Bearing 6204	7	8.0.1.00405	ABI 271
11	16/1	Cylindrical Gear Z=22, M1.5	1	0.735.5001.00	
12	16/1	Cylindrical Gear Z=24, M1.75	1	0.744.5015.00	0744240100
13	16/1	Shaft (turbine shaft 0.744.2401.00)	1	0.744.2009.00	
14	16/1	Key 5x5x20	1	8.4.1.01617	
15	16/1	Key	1	0.744.7100.00	
16	16/1	Cover	1	2.744.1310.00	
17	16/1	Spacer 32x20.3x2.5	2	0.104.7525.00	
18	16/1	Oil Seal 20x47x7	2	8.7.3.01395	RIAT36
19	16/1	Spacer 35.3x25.6x1.0	1	0.100.7510.00	
20	16/1	Spacer 40.3x46.7	2	0.457.7500.00	
21	16/1	Spacer	1	0.744.7104.00	
22	16/1	Pinion Shaft Z=12, M1.5	1	0.744.5011.00	
23	16/1	Pinion Shaft Z=14, M1.75	1	0.744.5009.00	
24	16/1	Spacer 44x30.3x1	1	0.102.7510.00	
25	16/1	Spacer 20.5x34.8x1	1	0.742.7510.00	
26	16/1	Pinion Shaft Z=10, M2	1	0.745.5005.00	
27	16/1	Gear with Bearing 6206	1	2.744.6010.00	
28	16/1	Pinion Shaft Z=10, M3	1	0.745.5000.00	
29	16/1	Oil Plug 72x10	2	8.7.0.00744	DO27631
30	16/1	Circlip I72	3	8.5.2.00131	
31	16/1	Bearing 6207	3	8.0.1.00870	ABI 289
32	16/1	Circlip E35	3	8.5.1.00005	
33	16/1	Shaft	1	0.745.3000.00	
34	16/1	Crown Gear Z=46, M3	1	0.745.6000.00	
35	16/1	Key 10x8x30	1	8.4.1.00993	
36	16/1	Ring with Keyway H=2.5 I.D.35	2	8.5.1.00583	
37	16/1	Oil Seal 35x72x10	1	8.7.3.00055	ABI 559
38	16/1	Key 8x7x16	1	8.4.1.01041	
39	16/1	Crown Gear Z=67, M2	1	0.745.6002.00	
40	16/1	Circlip I52	2	8.5.2.00038	
41	16/1	Oil Plug 52x7	1	8.7.0.00693	9510600000
42	16/1	Bearing 6205	2	8.0.1.00034	ABI 287
43	16/1	Bushing	1	0.744.7000.00	
44	16/1	Spacer	1	0.744.7106.00	
45	16/1	Ring with Keyway H=2 I.D. 30	1	8.5.1.01082	
46	16/1	Circlip E25	1	8.5.1.00004	
47	16/1	Oil Seal 8x22x7	1	8.7.3.01396	

GEARBOX D-745A (9.745.044.00)



POS.	Page	Description	N.Pieces	Item Number	Notes
48	16/1	Cap	1	0.735.7104.00	
49	16/1	Cover	1	0.735.1300.00	
50	16/1	Bolt TCEI M8x12 (8.8)	2	8.1.2.01718	
51	16/1	Key	1	0.744.7101.00	
52	16/1	Gear	1	2.744.5007.00	
53	16/1	Crown Gear Z=58, M1.5	1	0.744.6003.00	
54	16/1	Plug 3/8" GAS	1	8.6.5.00006	
55	16/1	Oil Plug	1	8.7.0.00743	9510651000
56	16/1	Circlip I62	2	8.5.2.00007	
57	16/1	Bearing 6007	2	8.0.1.00000	CP35016
58	16/1	Spacer 48x35.3x1.3	1	0.259.7513.00	
59	16/1	Gear Z=28, M2	1	0.745.6001.00	
60	16/1	Key 10x8x16	1	8.4.1.01658	
61	16/1	P.T.O. Shaft 1-3/8"-6 spline	1	0.745.3001.00	
62	16/1	Oil Seal 35x62x10	1	8.7.3.00003	9020265000
63	16/1	Brake Hub	1	0.744.7004.00	
64	16/1	Spring	1	0.735.7103.00	
65	16/1	Washer 8.4x14	2	8.3.2.00439	
66	16/1	Brake Band	1	2.744.7006.00	
67	16/1	Threaded Knob M8-F	1	8.9.1.01713	
68	16/1	Brake Pin	1	0.744.7005.00	
69	16/1	Key 10x8x25	1	8.4.1.00232	
70	16/1	Lever	1	2.744.7002.00	
71	16/1	O-Ring 3062	2	8.7.6.00191	
72	16/1	Spring Washer 40x20.4x1.5	1	8.5.5.01316	
73	16/1	Cotter Pin 4x35	1	8.4.7.00760	
74	16/1	Castle Nut M20x1.5	1	8.2.2.00997	
75	16/1	Rollpin 5x24	1	8.4.5.00934	
76	16/1	Handle Grip	1	1.721.7002.00	
77	16/1	Ball 5/16" 7.9 mm	2	8.5.9.00166	
78	16/1	Plug 1/2" GAS	1	8.6.7.00269	
79	16/1	Lever x I.D.	1	2.744.7013.00	
80	16/1	Locking Nut M20x1.5	1	0.744.7105.00	
81	16/1	Spacer 32x20.3x1	1	0.104.7510.00	
82	16/1	Crown Gear Z=35, M1.75	1	0.744.6007.00	
83	16/1	Key 5x5x10	1	8.4.1.01511	
84	16/1	Gear Z=15, M3.5	2	0.744.6008.00	

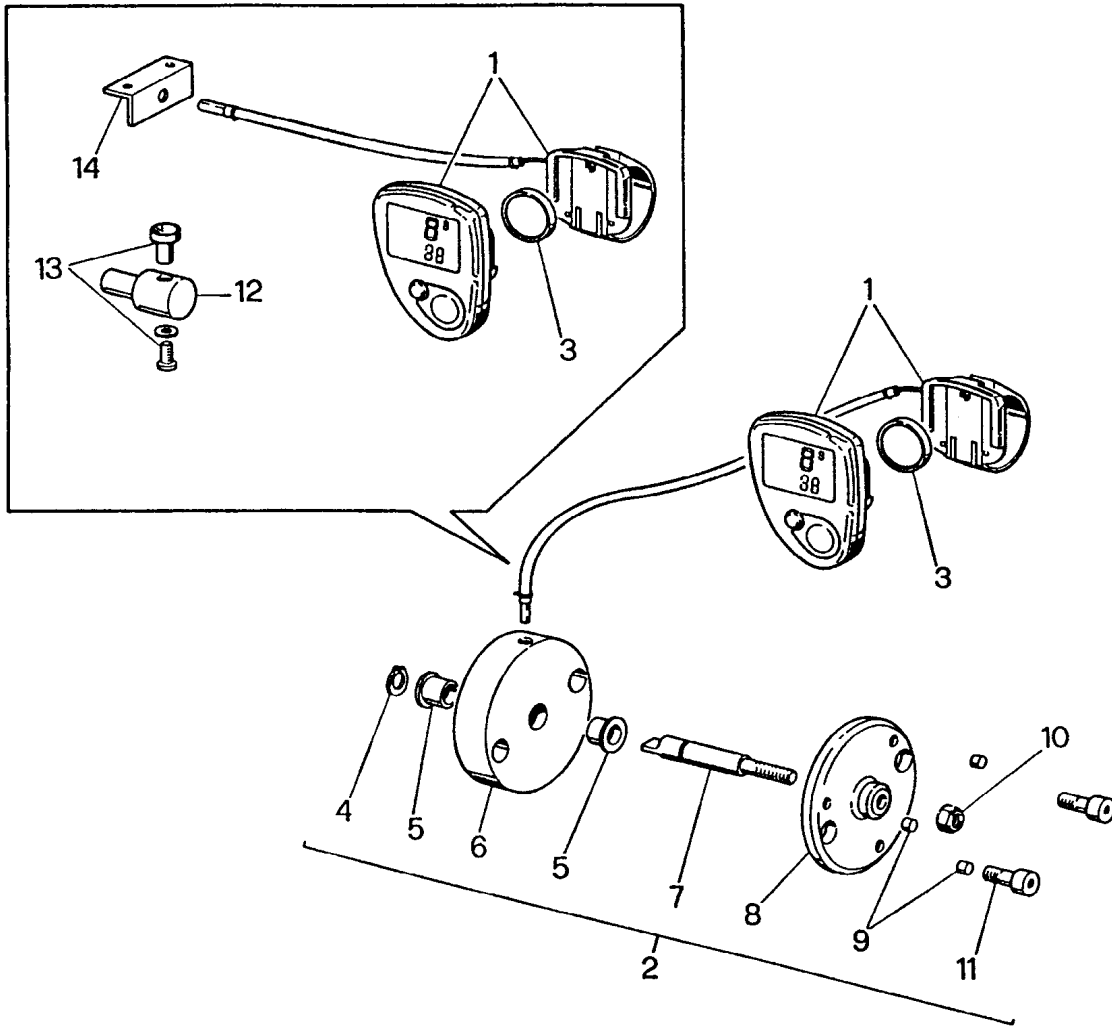

TACHOMETER VDO EURO/SPRINT



POS.	Page	Description	N.Pieces	Item Number	Notes
1	22	Tachometer VDO Euro/Sprint	1	5800501	
2	22	Velocity Sensor Complete	1	5800508	
3	22	Battery	1	5800504	
4	22	Circlip E8	1	5800503	
5	22	Bushing	2	5800502	
6	22	Sensor Support	1	5800052	
7	22	Velocity Sensor Shaft	1	5800054	
8	22	Magnet Support	1	5800053	
9	22	Magnet	3	5800505	
10	22	Nut/Nylock M5	1	5800211	
11	22	Bolt TCEI M5x12	2		
12	22	Single Magnet Support	1	8900034	
13	22	Magnet VDO	1		
14	22	Bracket	1	8900105	
1		\\			
2	22	Tachometer Complete (Euro)	1	TACHVDOEURO	
3		/			
		/			
1		\\			
3		\\			
12	22	Tachometer Complete (Sprint)	1	TACHVDOSPRINT	
13		/			
14		/			