

SERIES 890 GX



POS.	Page	Description	N.Pieces	Item Number	Notes
1	11	Plug Ø 133 Bauer M	1	8000122	
		Plug Ø 108 Bauer M	1	8900112	op
2	11	Rubber Ring Ø 133 Bauer	2	8001112	
		Rubber Ring Ø 108 Bauer	2	5801142	op
3	11	Crossover Pipe Ø 133 Bauer	1	8900018	
		Crossover Pipe Ø 108 Bauer	1	8900046	op
4	11	Hosetail Coupler Bauer Ø 133 Male zinc	2	8001102	
		Hosetail Coupler Bauer Ø 108 Male zinc	2	5801138	op
5	11	Clamp 120 P	4	8000103	
		Clamp 110 P	4	5800139	
6	11	Rubber Hose 120x134	1	8000104	4.5 meters
		Rubber Hose 102x116	1	5800113	4.5 meters/op
7	11	Key 5x9	1	8900205	
8	11	Bolt TE M8x25 zinc	12	8900204	
9	11	Turbine Flange	1	8900030	
10	11	O-Ring 41050 (turbine cover)	1	5800204	
11	11	Washer 1/16"	4	8900202	
12	11	Bolt TCEI M8x20 Inox	4	8900203	
13	11	Mechanical Seal BT PR/FN 20 L	1	8900201	
14	11	Impeller	1	5800023	
15	11	Nut M16x1,5 Inox	1	8900206	
16	11	Turbine Body	1	5800021	
17	11	Nozzle	1	5800214	Ø ...
18	11	Gasket	1	5800025	
19	11	O-Ring 108	2	5800213	
20	11	Nut M5 medio Inox	2	5800211	
21	11	Flapper	1	5800028	
22	11	By-Pass Valve Shaft	1	5800027	
23	11	Rollpin Ø 5	1	5800212	
24	11	Bolt TE M5x20 Inox	2	5800210	
25	11	By-Pass Lever	1	8900040	
26	11	By-Pass Stop	1	5800030	
27	11	Threaded Knob	1	5800102	
28	11	P.T.O. cover	1	8900032	
29	11	Rubber Grip 25x10	2	5800109	
30	11	Drive Cover	1	8900031	
31	11	Pressure Gauge GJ 1/4	1	5800115	
32	11	Clamp 104-115	4	5800114	
33	11	Rubber Hose 15 102x116	1	5800113	1.04 meters
34	11	By-Pass rod	1	8900035	
35	11	Inlet Coupler Hosetail x Flange	1	8900017	
36	11	Gasket DN100	1	8000123	
37	11	Inlet Elbow with Flange	1	8900016+8000004	
38	11	Cap 3" F	1	8000121	
39	11	Grease Zirk M6	3	5800112	
40	11	Ring UM 110-135-12	2	8000106	
41	11	Circlip E110	1	8000110	

SERIES 890 GX



POS.	Page	Description	N.Pieces	Item Number	Notes
42	11	Bearing 6222	1	8000108	
43	11	Bearing Support	1	8000003	
44	11	Shaft Sleeve S.S.	1	8900024	
45	11	O-Ring 2400 (per bussola Inox)	1	8900104	
46	11	Reel Complete	1	8000001	
47	11	Drum Tooth M16x60 with nut	16	7000036	
48	11	Clamp PE Ø 100 (90-105)	3	5900102	
		Clamp PE Ø 110 (104-115)	3	5800114	
		Clamp PE Ø 120 (115-130)	3	8000120	
		Clamp PE Ø 125 (120-134)	3	8000111	
49	11	PET Hose Coupler	1	5500033	Ø PE
50	11	PET Hose (specify size and length)	1	TUBPOL...	Ø PE
51	11	Shut-Off Cable	1	5500041	ml...
52	11	By-Pass Stop	1	5800058	
53	11	Spring	1	8900048	
54	11	Overwind Bar Complete	1	8900010	
55	11	Reelside Cover	16	8000005	
		Reelside Cover	16	8900047	op
56	11	Bearing UCP 210	1	7000111	
57	11	Circlip E50	1	7000109	
58	11	Sprocket 1/2" S	2	5500037	z...
59	11	Cursor	1	5801006	
60	11	Cursor Finger	1	5800050	
61	11	Circlip I35	1	5800144	
62	11	Grease Zirk M6	1	5800112	
63	11	Hoseguide Bar	1	7000008	
64	11	Bearing UCPA 206	2	6000104	
65	11	Master Link 1/2" S	1	5800120	
66	11	Chain 1/2" S	1	5800119	3.8 meters
67	11	Primary Chain Cover (back)	2	5700028	
68	11	Primary Chain Cover	1	8000006	
69	11	Gearbox Shut-Off Cable	1	5500025	ml...
70	11	Shut-Off Bar	1	8900004	
71	11	Lifting Frame	1	8900003	
72	11	Shut-Off Lever	1	8900028	
73	11	Spring	1	5700013	
74	11	Hoseguide Fork	1	8900011	
75	11	Hydraulic Distributor (4 lever)	1	7000303	op
76	11	R-Clip Ø 4	4		
77	11	Hoseguide Roller Shaft	1	5900007	
78	11	Hoseguide Roller PVC	1	7000026	
79	11	Lifting Frame Guide (upper)	2	8900008	
80	11	Lifting Frame Guide (lower)	2	8900007	
81	11	Pin	2	5800042	
82	11	R-Clip Ø 3	2	COOPAMA03	
83	11	Circlip E25	8	7000114	
84	11	Hydraulic Cylinder Pin (upper)	4	7000028	

SERIES 890 GX



POS.	Page	Description	N.Pieces	Item Number	Notes
85	11	Right Foot	1	8900005	sx
		Left Foot	1	8900006	dx
86	11	Hydraulic Cylinder	2	8900014	
87	11	Nipple 3/8"-1/4"	4	7000307	
88	11	Gasket Washer 3/8"	4		
89	11	Hydraulic Hose 1/4" L=2150	4	5800128	
90	11	Terret Frame	1	8900001	
91	11	P.T.O. Handle	1	5800041	
92	11	Anti-Return Pawl Complete	1	8900023	
93	11	Anti-Return Spring	1	5500040	
94	11	Brake Tightner Support	1	8900025	
95	11	Brake Tightner	1	8900113	i0.735.7101.00
96	11	Idler Sprocket Shaft	1	8900012	
97	11	Idler Sprocket 1" Z10	1	8900027	
98	11	Idler Support	1	8900026	
99	11	Idler Cover	1	8900045	
100	11	U-Bolt 4"	1	8900106	
101	11	Crossover Support	1	8900019	
102	11	Hydraulic Distributor (3 lever)	1	7000302	op
103	11	Hydraulic Distributor (2 lever)	1	7000301	
104	11	Hydraulic Hose 1/4" L=4300	2	9000112	op
105	11	Hydraulic Hose 3/8" L=2000	2	8900107	
106	11	Tractor Coupler M	2	7000309	
107	11	Nipple 3/8"-1/2"	2	8900109	
108	11	Nipple 3/8"-3/8"	2	8900108	
109	11	Nipple 3/8"-1/4"	6	7000307	
110	11	Hydraulic Hose 1/4" L=3900	2	7000310	
111	11	Hydraulic Hose 1/4" L=700	2	7000306	
112	11	Hydraulic Chassis Jack	1	8900015	
113	11	Coupler	1	5500042	op
114	11	Hydraulic Motor Mounting Bracket	1	9900033	op
115	11	Gear Z13 M7	1	5800402	op-f.
		Gear Z13 M7	3	7000403	op-d.
116	11	Hydraulic Motor GFL300	1	7000401	op
117	11	Turntable Bearing	1	8000107	
118	11	Turntable Gear	1	7000402	op
119	11	Towing Hitch Pin	2	7000032	
120	11	R-Clip Ø 5	2	COOP05AMA	
121	11	Towing Hitch	1	9900036	
122	11	Chassis	1	8900002	
123	11	T-Coupler 1/4"	2	6000111	
124	11	Hydraulic Hose Bracket	8	7000047	
125	11	Tachometer Complete	1	TACHVDOSPRINT	v.pag.22
126	11	Drive Sprocket Washer	1	7000072	
127	11	Drive Sprocket 1" S Z12	1	8001016	
128	11	Spacer 1"	1	7000073	
129	11	Gearbox Comer D 744 A	1	8900101	v.pag.21

SERIES 890 GX



POS.	Page	Description	N.Pieces	Item Number	Notes
130	11	Brake Pad	1	5800143	i2.744.7006.00
131	11	Gearbox Oil Plug	1		i8.6.7.00269
132	11	Coupler Bauer Ø 133 F	1	8001109	gr
		Coupler Bauer Ø 108 F	1	5801136	gr-op
133	11	Gearbox Shut-Off Lever	1	8900029	
134	11	Gearbox Shut-Off Cable	1	5500025	ml...
135	11	Master Link catena 1"	1	7000104	
136	11	Double Axle Support	2	8900021	op
137	11	Nut/Nylock M30	4	8900115	op
138	11	Bolt TE M30x250	2	8900114	op
139	11	Wheel 10.0/75-15.3 PR10	4	6000101	op
140	11	Double Axle Spindle Assembly	2	8900020	op
141	11	Spindle Lug Nut Stud (5 lug)	20	5800153	
142	11	Lug Nut	20	5800154	
143	11	Single Axle Assembly	2	8900013	
144	11	Spindle Lug Nut Stud (6 lug)	12	5800151	
145	11	Wheel 11.5/80-15.3 12PR	2	8000105	
146	11	Lug Nut	12	5800152	
147	11	Hydraulic Hose 1/4" L=7000	2	8900111	op
148	11	Chain 1" S FKK	1	7000103	8.97 meters
149	11	Turntable Locking Pin	1	7000032	
150	11	Boom Lifting Frame	1	8900041	op
151	11	Boom Lifting frame Fork	1	8900042	op
152	11	Mounting Plate	4	8900043	op
153	11	Chain	2	CATGENOV	1 meter
154	11	Hydraulic Cylinder	2	9900029	op
155	11	Boom Shut-Off Bar	1	8900009	op
156	11	Nipple 3/8"-1/4"	4	7000307	op
157	11	Hydraulic Hose 1/4" L=1800	4	8900110	op
158	11	T-Coupler 1/4"	2	6000111	op
159	11	Nipple 3/8"-1/4"	2	7000307	op

SERIES 890 GX



POS.	Page	Description	N.Pieces	Item Number	Notes
7 8 9 10 11 12 13 14 15 16 17 18 19 20 21 22 23 24	11	/ Turbine complete T3M	1	TUR580M	

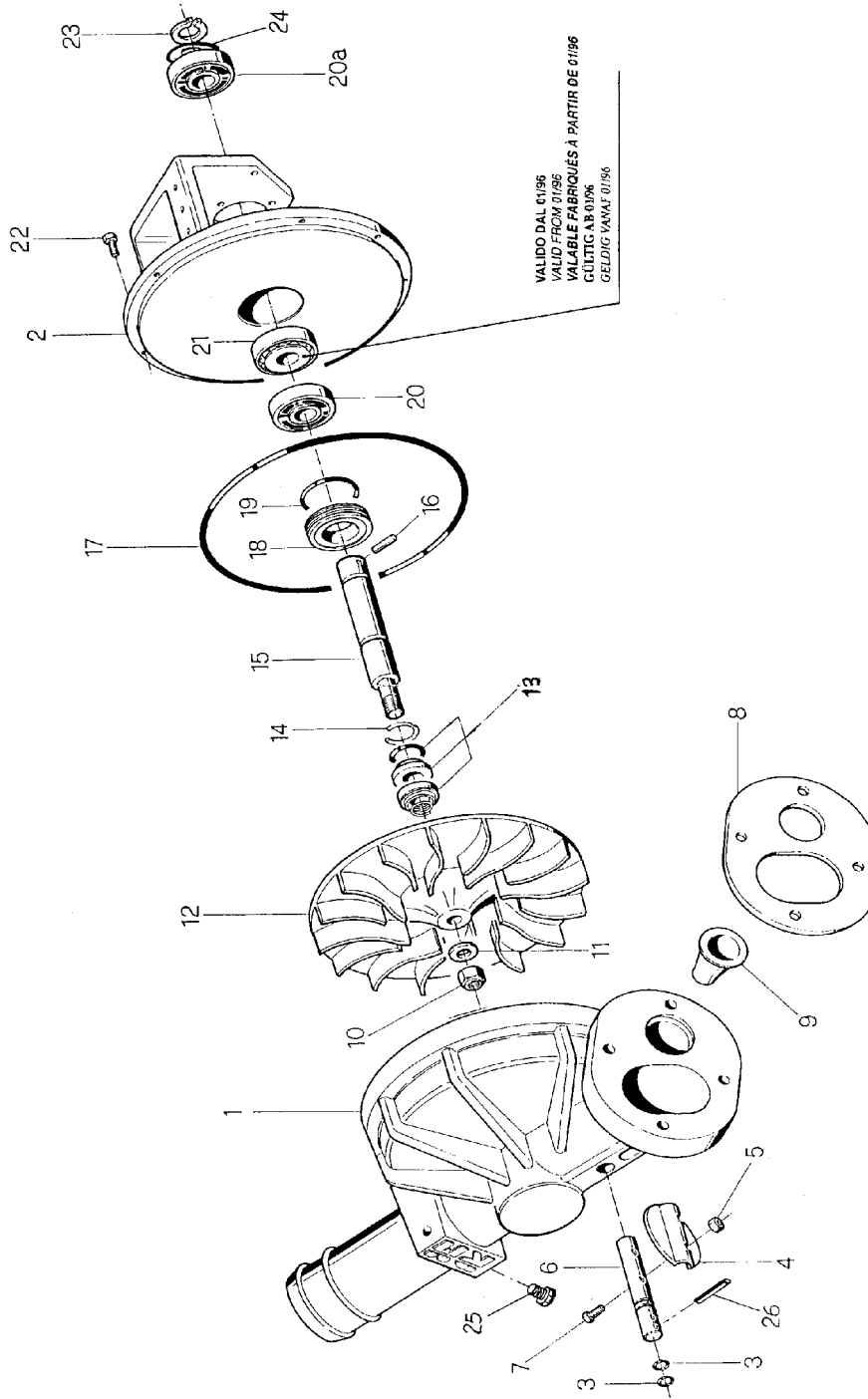

TURBINE T3(cod.TUR580)-T3.1 FLANGED (cod.TUR5801)



POS.	Page	Description	N.Pieces	Item Number	Notes	
1	14	Turbine Body T3	1	5800021	rif.T3	
	14	Turbine Body T3.1	1	5801021	rif.T3.1	
2	14	Cover	1	5800020		
3	14	O-Ring 108	2	5800213		
4	14	Flapper	1	5800028		
5	14	Nut S.S. M5	2	5800211		
6	14	By-Pass Valve Shaft	1	5800027		
7	14	Bolt M5x20 S.S.	2	5800210		
8	14	Rubber Gasket	1	5800025		
9	14	Nozzle	1	5800214	Ø ...	
10	14	Locking Nut M16	1	5800209		
11	14	Spring Washer S.S. 17x30x3	1	5800218		
12	14	Impeller	1	5800023		
13	14	Mechanical Seal standard	1	5800201	8009201	
	14	Mechanical Seal stainless	1	5800201W	op	
14	14	Ring A25	1	5800202		
15	14	Shaft S.S.	1	5800024		
16	14	Rollpin 6x50	1	5800205		
17	14	O-Ring 41050	1	5800204		
18	14	Mechanical Seal Spacer PVC	1	5800022		
19	14	O-Ring 3181	1	5800203		
20	14	Bearing	1	5800215		
20a	14	Bearing INA	1	5801215	f.31/12/95	
	14	Bearing	1	5800215	d.01/01/96	
21	14	Bearing 30205	1	5800217	d.01/01/96	
22	14	Bolt TCEI M8x25	12	5800207		
23	14	Circlip E25	1	5800206		
24	14	Washer INA	1	5800216		
25	14	Plug zinc GJ 1/4"	1	5800208		
26	14	Rollpin 5x25	1	5800212		
2						
10						
11						
12						
13						
14						
15						
16	14		Turbine Kit T3-T3.1	1	TUR580KIT	
17						
18						
19						
20						
20a						
21						
23						
24						

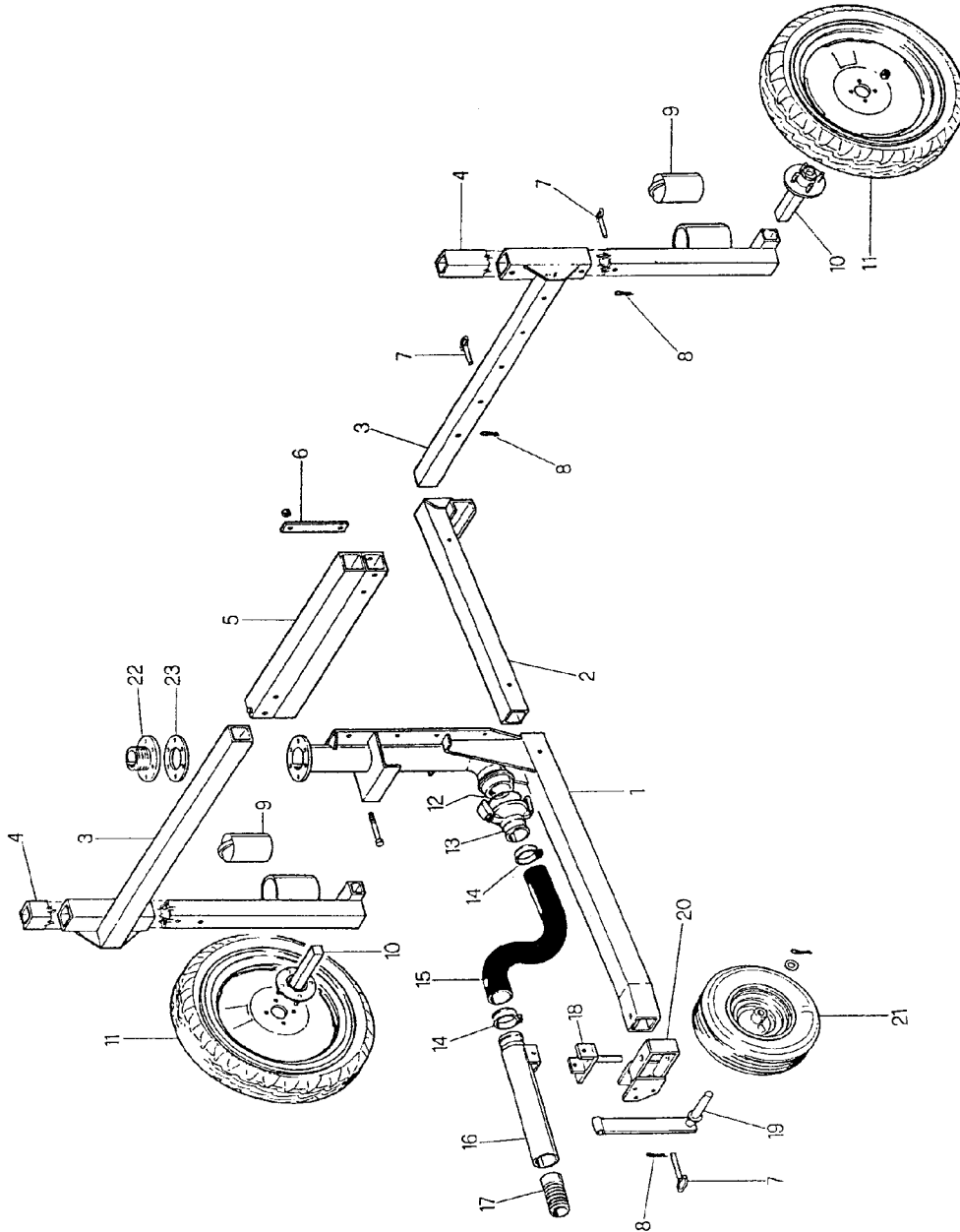

SERIES 580-600 GX TROLLEY (VERSION '98)



POS.	Page	Description	N.Pieces	Item Number	Notes
1	28	Trolley Body	1	58020189	
2	28	Drawbar	1	580201810	
3	28	Leg Support	2	58020185	
4	28	Leg	2	58020186	
5	28	Head	1	58020184	
6	28	Head Mounting Bracket	2	58020181	
7	28	Pin	5	5800042	
8	28	R-Clip Ø 3	5	COOP03AMA	
9	28	Weight	2	BILLETTE	.3 meters
10	28	Hub Assembly 4 lug 35 L=200	2	5800103	
11	28	Wheel 125/70 D15	2	5800104	pn
12	28	Rubber Ring Ø 80 Ferrari	1		c.13
13	28	Coupler Ø 80 with Rubber Ring	1	580201811	c.12
14	28	Clamp 86-95	2	5800137	
15	28	Rubber Hose 10 80 x 93	1	5500102	1.1 meters
16	28	Attachment PE-Trolley	1	58020188	
17	28	Barbed Nipple PE	1	5500033	gr - Ø PE
18	28	Pivot Pin	1	58020187	
19	28	Wheel Support	1	58020183	
20	28	Wheel pivot Bracket	1	58020182	
21	28	Wheel 5.00 x 8"	1	5800149	
22	28	Coupler for Ranger	1	5800044	Ø PE -100-
		Coupler for Sinkro	1	5700039	110
23	28	Gasket	1	58000461	Ø PE 82
1		- - - Trolley Bare 580-600GX - - -			
2					
3					
4					
5					
6	28			1	5802018
13					
16					
18					
19					
20					
1÷21	28	Trolley Complete	1	CARR5803	

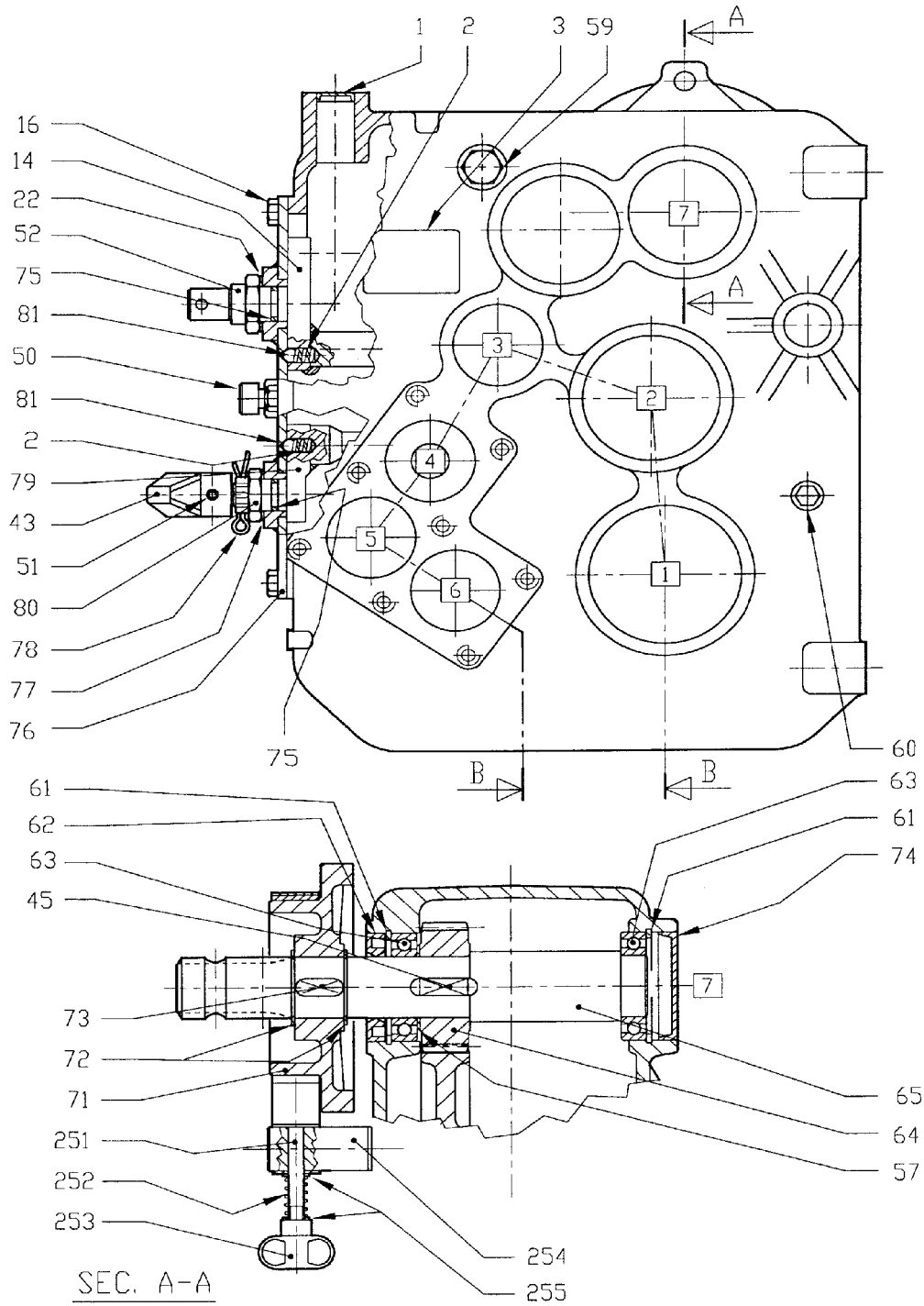

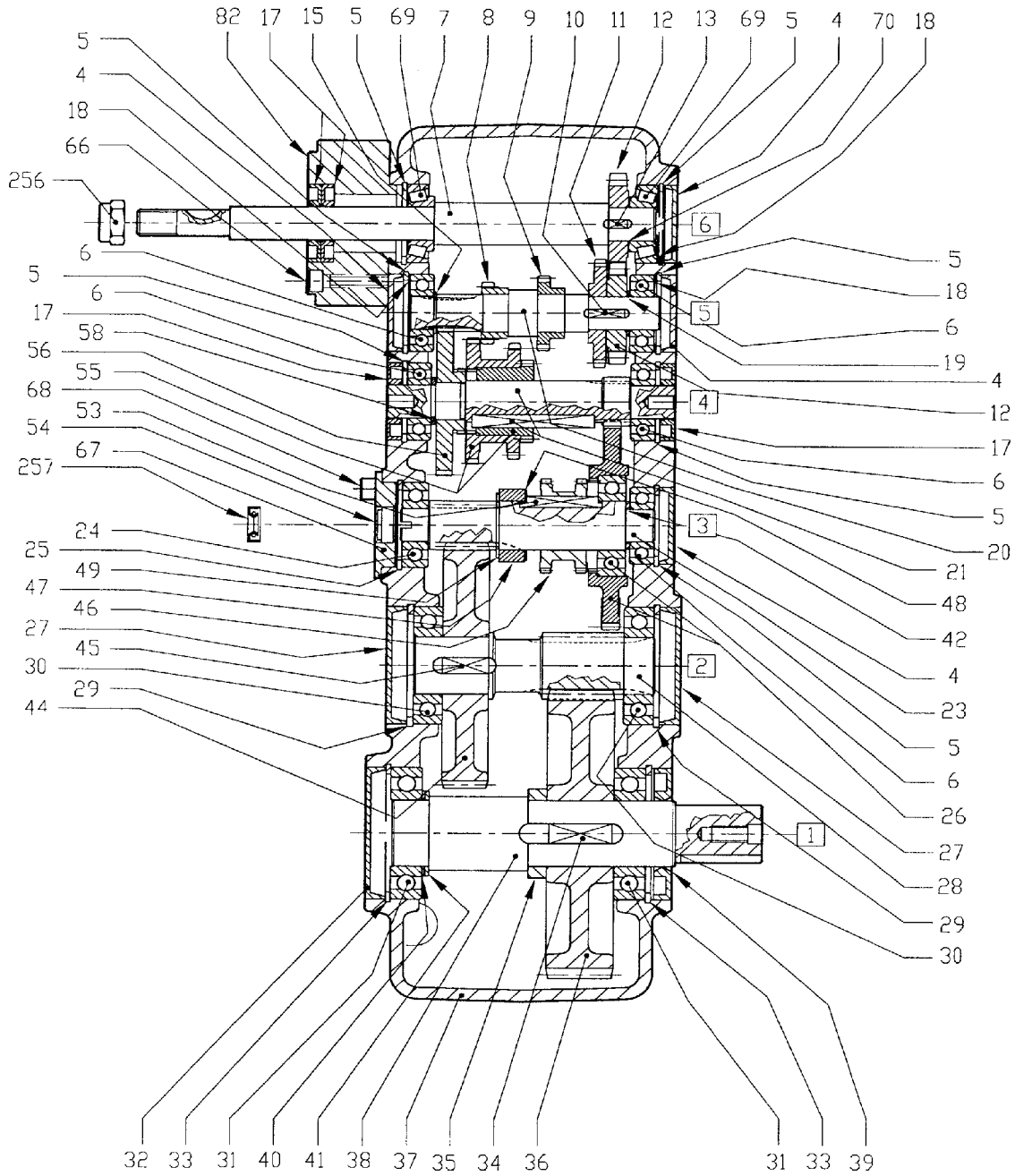

SEC. B-B

GEARBOX D-744A (744.057.00)



POS.	Page	Description	N.Pieces	Item Number	Notes
1	21	Plug	1	01202.069.041	
2	21	Spring	2	0.721.7101.00	
3	21	Serial Plate "COMER"	1	0.124.7101.00	
4	21	Oil Plug 47x7	4	8.7.0.01362	
5	21	Circlip I47	7	8.5.2.01290	
6	21	Bearing 6204	5	8.0.1.00405	
7	21	Input Shaft	1	0.744.2401.00	
8	21	Cylindrical Gear Z=22, M1.5	1	0.735.5001.00	
9	21	Cylindrical Gear Z=24, M1.75	1	0.744.5015.00	
10	21	Key 5x5x20	1	8.4.1.01617	
11	21	Cylindrical Crown Gear Z=3, M1.75	1	0.744.6007.00	
12	21	Gear Z=21, M2.5	2	0.744.6018.00	
13	21	Key 5x5x10	1	8.4.1.01511	
14	21	Lever	1	2.744.7018.00	
15	21	Circlip E20	1	8.5.1.00261	
16	21	Bolt TE M8x18 (8.8)	6	8.1.1.01676	
17	21	Oil Seal 20x47x7	4	8.7.3.01395	
18	21	Spacer 40.3x46.7	3	0.457.7500.00	
19	21	Spacer 20.9x26.9x4	1	0.744.7104.00	
20	21	Pinion Shaft Z=12, M1.5	1	0.744.5011.00	
21	21	Pinion Shaft with key	1	2.744.5029.00	
22	21	Spacer 32x20.3x1	1	0.104.7510.00	
23	21	Pinion Shaft Z=12, M2	1	0.744.5031.00	
24	21	Bearing 6304	1	8.0.1.00035	
25	21	Circlip I52	1	8.5.2.00038	
26	21	Gear with Bearing 6206	1	2.744.6010.00	
27	21	Oil Plug 72x10	2	8.7.0.00744	
28	21	Pinion Shaft Z=12, M2.75	1	0.744.5004.00	
29	21	Circlip I72	2	8.5.2.00131	
30	21	Bearing 6207	2	8.0.1.00870	
31	21	Bearing 6208	2	8.0.1.00871	
32	21	Oil Plug 80x10	1	8.7.0.00790	
33	21	Circlip I80	2	8.5.2.00030	
34	21	Key 12x8x35	1	8.4.1.00966	
35	21	Spacer 40.3x54x10.5	1	0.285.7102.00	
36	21	Crown Gear Z=62, M2.75	1	0.744.6000.00	
37	21	Casing	1	0.744.0302.00	
38	21	Output Shaft	1	0.744.3004.00	
39	21	Oil Seal 40x80x10	1	8.7.3.00027	
40	21	Spacer 51.5x40.3x1	1	0.244.7510.00	
41	21	Spacer 51.5x40.3x2.5	1	0.244.7525.00	
42	21	Spacer 20.5x34.8x1	1	0.742.7510.00	
43	21	Handle	1	1.721.7002.00	
44	21	Crown Gear Z=73, M2	1	0.744.6001.00	
45	21	Key 10x8x25	2	8.4.1.00992	
46	21	Bushing	1	0.744.7000.00	
47	21	Spacer 30.1x44.5x15	1	0.744.7106.00	

GEARBOX D-744A (744.057.00)



POS.	Page	Description	N.Pieces	Item Number	Notes
48	21	Spacer 44x30.3x1	1	0.102.7510.00	
49	21	Circlip E30 H=2	1	8.5.1.01082	
50	21	Oil Breather 1/2" GAS	1	8.6.7.00269	
51	21	Rollpin 5x24	1	8.4.5.00934	
52	21	Locking Nut M20x1.5	1	0.744.7105.00	
53	21	Key	1	0.744.7112.00	
54	21	Oil Cap 22x4	1	8.7.0.01343	
55	21	Compound Gear	1	2.744.5007.00	
56	21	Grown Gear Z=58, M1.5	1	0.744.6003.00	
57	21	Spacer 48x35.3x1.3	1	0.259.7513.00	
58	21	Spacer 32x20.3x2.5	1	0.104.7525.00	
59	21	Oil Sight Glass 3/8" GAS	1	8.6.4.00273	
60	21	Plug 3/8" GAS	1	8.6.5.00006	
61	21	Circlip I62	2	8.5.2.00007	
62	21	Oil Seal 35x62x10	1	8.7.3.00003	
63	21	Bearing 6007	2	8.0.1.00000	
64	21	Pinion Gear Z=34, M2	1	0.744.5002.00	
65	21	P.T.O. Shaft 1-3/8" 6 spline	1	0.744.3200.00	
66	21	Bolt TCEI M8x40 (8.8)	4	8.1.2.01723	
67	21	Cover	1	0.735.1300.00	
68	21	Bolt TCEI M8x12 (8.8)	2	8.1.2.01718	
69	21	Bearing 30204	2	8.0.9.02320	
70	21	Spacer 32x20.3x.3	1	0.104.7503.00	
71	21	Brake Drum	1	0.743.7005.00	
72	21	Circlip E35	2	8.5.1.00005	
73	21	Key 10x8x25	1	8.4.1.00232	
74	21	Oil Plug 62x10	1	8.7.0.00743	
75	21	O-Ring 3062	2	8.7.6.00191	
76	21	Cover 4 Speed	1	2.744.1321.00	
77	21	Spring Washer 40x20.4x1.5	1	8.5.5.01316	
78	21	Cotter Pin 4x35	1	8.4.7.00760	
79	21	Lever 4 Speed	1	2.744.7002.00	
80	21	Crown Nut M20x1.5	1	8.2.2.00997	
81	21	Ball 5/16" (7.9 mm)	2	8.5.9.00166	
82	21	Flange	1	0.744.7008.00	
		A.744.007	1		
251	21	Brake Band	1	2.744.7006.00	
252	21	Spring	1	0.735.7103.00	
253	21	Threaded Knob M8 F	1	8.9.1.01713	
254	21	Brake Support	1	0.735.7101.00	
255	21	Flat Washer 8.4x14	2	8.3.2.00439	
256	21	Locking Nut M16x1.5	1	8.2.6.00868	
257	21	Oil Seal 8x22x7	1	8.7.3.01396	

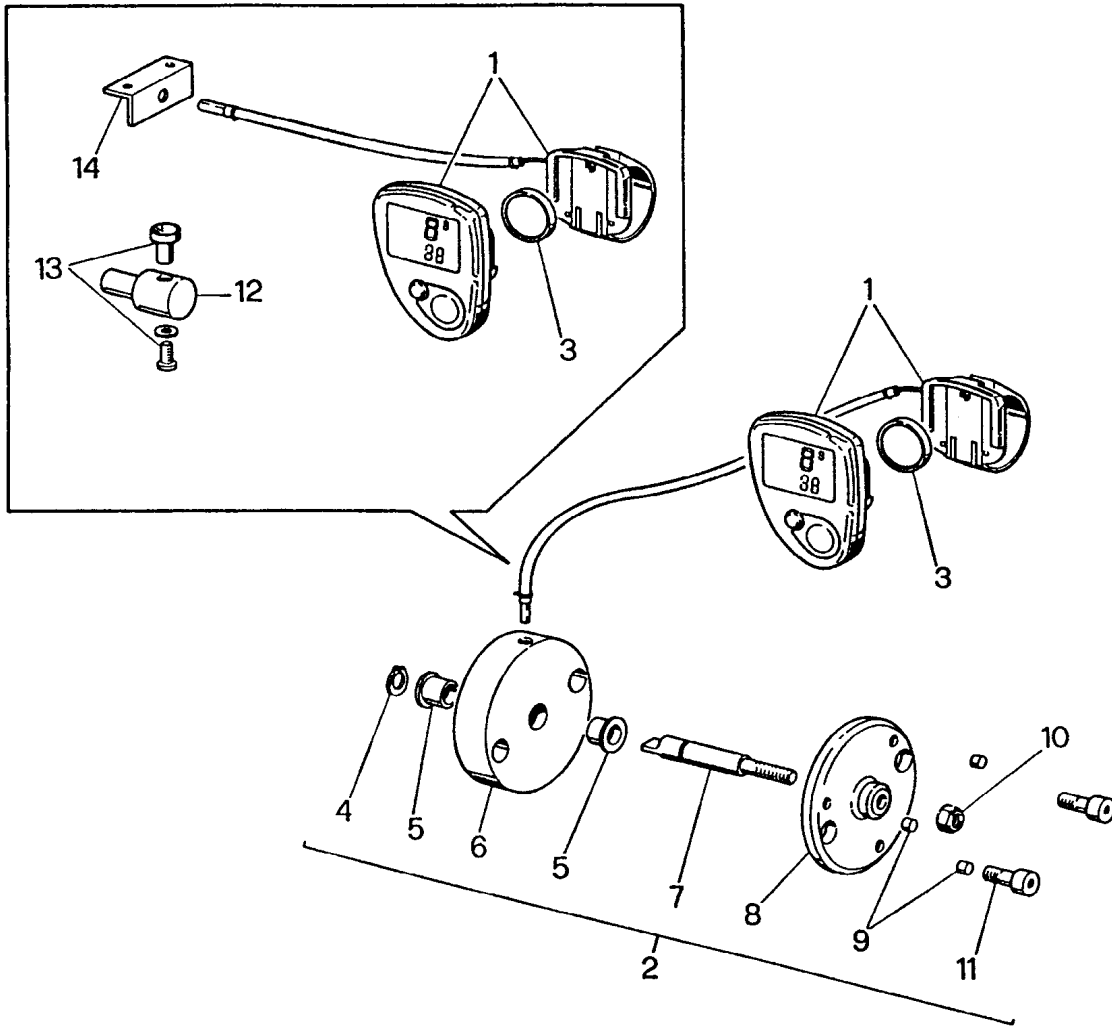

TACHOMETER VDO EURO/SPRINT



POS.	Page	Description	N.Pieces	Item Number	Notes
1	22	Tachometer VDO Euro/Sprint	1	5800501	
2	22	Velocity Sensor Complete	1	5800508	
3	22	Battery	1	5800504	
4	22	Circlip E8	1	5800503	
5	22	Bushing	2	5800502	
6	22	Sensor Support	1	5800052	
7	22	Velocity Sensor Shaft	1	5800054	
8	22	Magnet Support	1	5800053	
9	22	Magnet	3	5800505	
10	22	Nut/Nylock M5	1	5800211	
11	22	Bolt TCEI M5x12	2		
12	22	Single Magnet Support	1	8900034	
13	22	Magnet VDO	1		
14	22	Bracket	1	8900105	
1		\\			
2	22	Tachometer Complete (Euro)	1	TACHVDOEURO	
3		/			
		/			
1		\\			
3		\\			
12	22	Tachometer Complete (Sprint)	1	TACHVDOSPRINT	
13		/			
14		/			